

Ingredients for simple harmonic motion (SHM)

Mass on a spring

x – displacement from equilibrium

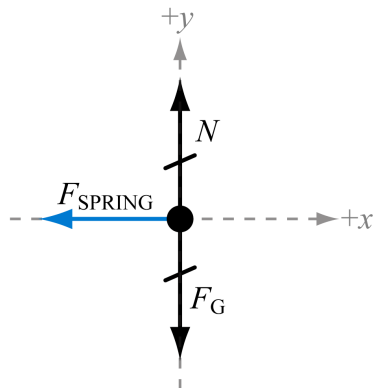
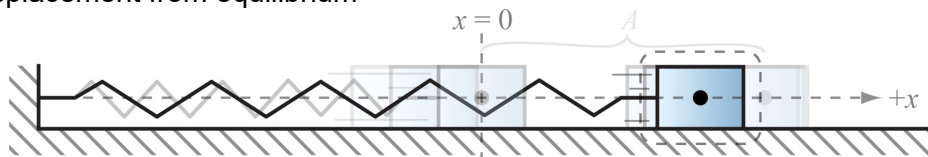

Spring force
Direction: Restoring
Magnitude: \propto Displacement

$$a_x = \frac{\Sigma F_x}{m}$$

$$a_x = \frac{-k|\Delta x|}{m}$$

$$a_x = \frac{-kx}{m}$$

$$a_x = -\frac{k}{m}x$$

Ideal pendulum

θ – angular displacement from equilibrium

Gravitational torque
Direction: Restoring
Magnitude: Approx. \propto Angular displacement

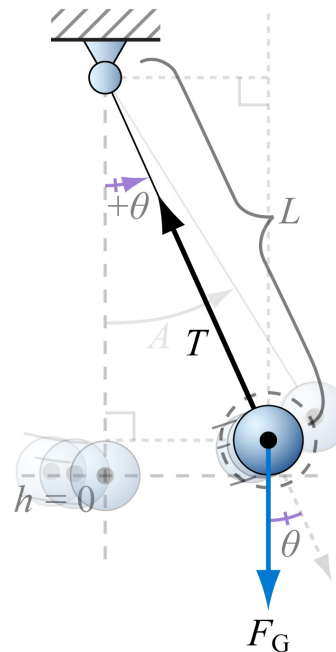

$$\alpha = \frac{\Sigma \tau}{I}$$

$$\alpha = \frac{-mgL \sin \theta}{mL^2}$$

$$\alpha = -\frac{g}{L} \sin \theta$$

For small angles,

$$\alpha \approx -\frac{g}{L} \theta$$

$$\omega^2 = \frac{k}{m}$$

$$x(t) = A \cos\left(\sqrt{\frac{k}{m}}t + \delta\right) = A \cos\left(\frac{2\pi}{T}t + \delta\right)$$

$$\omega = \frac{2\pi}{T} \Rightarrow T = \frac{2\pi}{\omega}$$

$$T = \frac{1}{f} = 2\pi\sqrt{\frac{m}{k}}$$

$$\Sigma_{\text{MASS \& SPRING}} ME = \frac{1}{2}mv_x^2 + \frac{1}{2}kx^2$$

ω – angular velocity of UCM that completes one lap in the same duration of time that SHM of interest completes one cycle of oscillation

A – amplitude (maximum linear or angular distance from equilibrium)

T – period (repetition time)

When magnitude of restoring net force (torque) is \propto (angular) displacement, T is independent of A

f – frequency (oscillations per unit time)

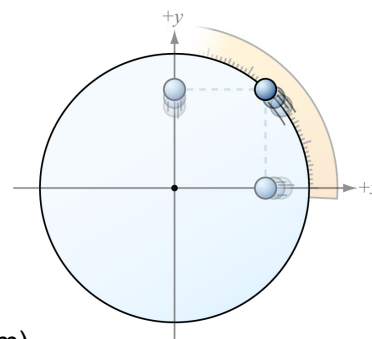

$$\omega^2 = \frac{g}{L}$$

$$\theta(t) = A \cos\left(\sqrt{\frac{g}{L}}t + \delta\right) = A \cos\left(\frac{2\pi}{T}t + \delta\right)$$

$$\omega = \frac{2\pi}{T} \Rightarrow T = \frac{2\pi}{\omega}$$

$$T = \frac{1}{f} = 2\pi\sqrt{\frac{L}{g}}$$

$$\Sigma_{\text{BOB \& } \oplus} ME = \frac{1}{2}mv_{\text{TAN}}^2 + mgL(1 - \cos \theta)$$

$$\Sigma_{\text{BOB \& } \oplus} ME \approx \frac{1}{2}mv_{\text{TAN}}^2 + \frac{mg}{2L}(L\theta)^2$$